



## **Pinflex Flexible Coupling**

[Brochure](#)

**RENOLD** | Couplings

# Contents

Renold Couplings	3
Pinflex	4
Keyway dimensions	5
Pinflex coupling dimensions	6
Component spares	7
Pinflex brakedrum coupling	8
Pinflex shearpin coupling	9
Global services	10



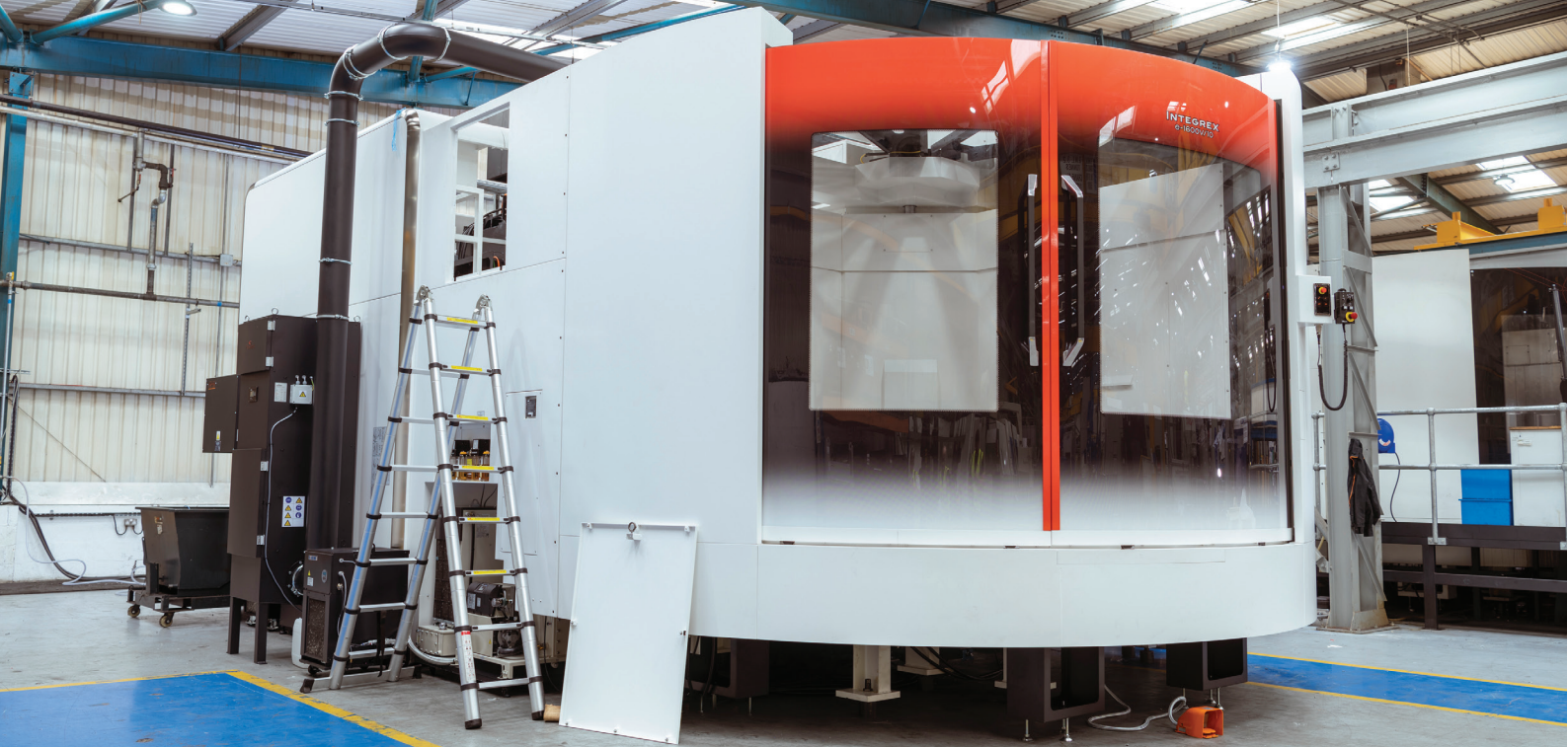

## Innovation Everyday

Renold have been driving industry forward through innovation since 1879. Renold Couplings drives industry the world over, from marine, cranes and hoists to manufacture, mass transportation and the pulp and paper industry. Our couplings connect machines to machines through stock solutions and bespoke-crafted connections, all manufactured in our high-tech engineering factories.

### Engineering capability

A team of in-house design engineers work to continuously improve the existing product range, introduce new products and deliver innovative new solutions to our customers challenges.

### British manufacturer

Since 1946 Renold Couplings have manufactured a full range of couplings and clutches.

Based in Cardiff, UK, we control the full design and manufacture process, bringing class leading quality and complete customer peace of mind.

### Worldwide support

With manufacturing facilities in 4 continents and support offices in over 30 countries Renold Couplings can offer service that understands the requirements and challenges of your particular market.

### Availability

Renold Couplings holds significant stock of standard items and component parts both in our UK facility and with our partners around the world.

Controlling the full manufacturing process, Renold Couplings can deliver responsive lead times for manufactured parts.

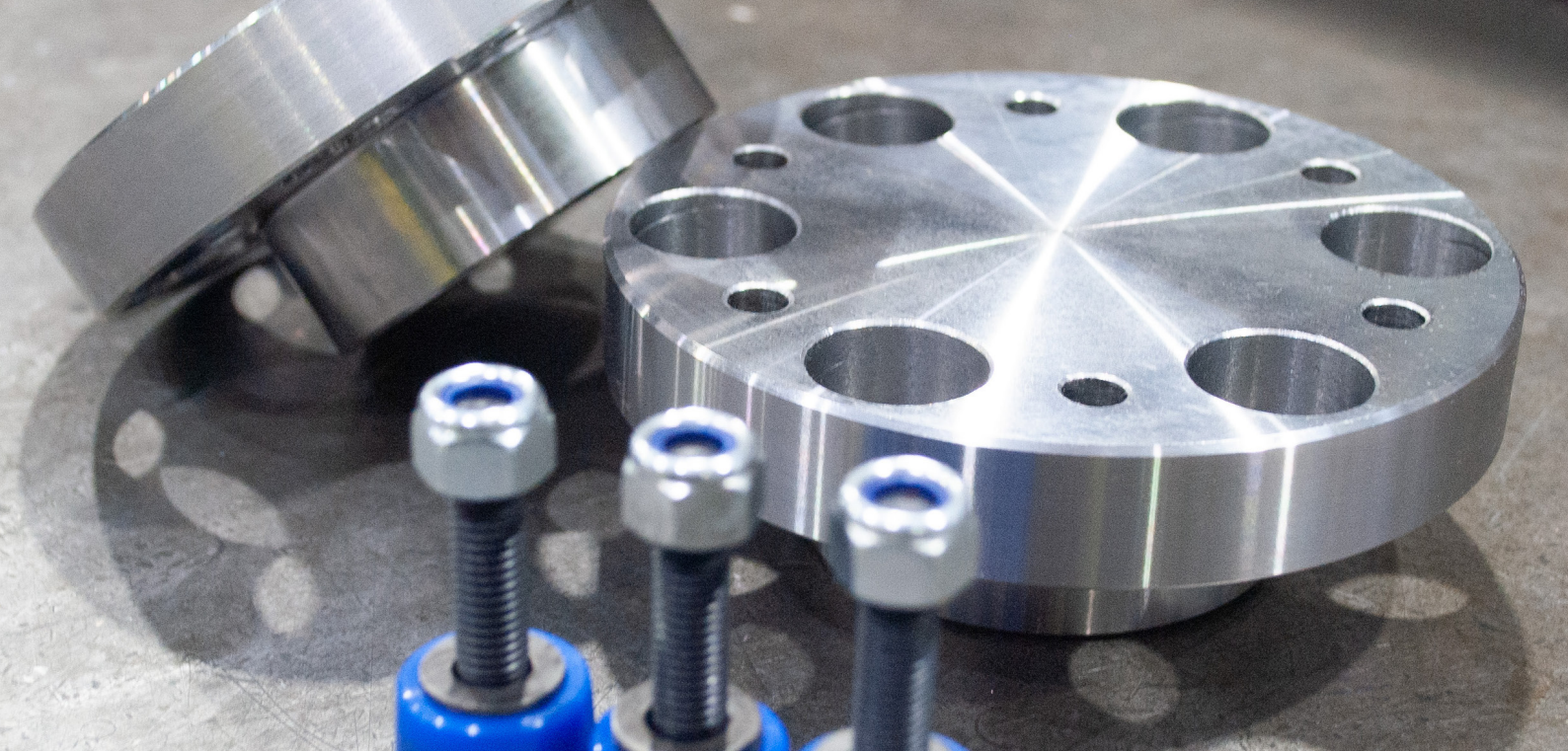

## Pinflex

Pin and Buffer Coupling – compact, robust and adaptable.

### Coupling capacity

- Maximum power @ 100RPM: 340kW
- Maximum torque: 32,500Nm

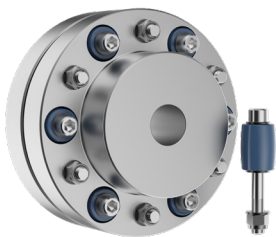

### Standard range comprises

- Shaft to Shaft
- Shear Pin
- Brake Drum/Disc

### Applications

- Conveyors
- Escalators
- Mixers
- Pumps
- General Industrial Applications

### Features and benefits

- Steel half bodies, strong yet compact
- Heavy duty pin and buffer coupling – for heavy shock load conditions
- Torsionally flexible – shock absorbing, extending machine life
- Maintenance free – minimum number of wearing parts
- Misalignment capabilities allowing flexibility in installation
- Common half bodies – minimise stock holding
- Polyurethane buffers, reliable/flexible and temperature resistant
- Modular construction – available as coupling, brakedrum and shear pin designs
- Taper bores available for ease of maintenance
- Modular Construction – use only the required number of pin and buffers for your application's torque. Available with brakedrum and shear pin options



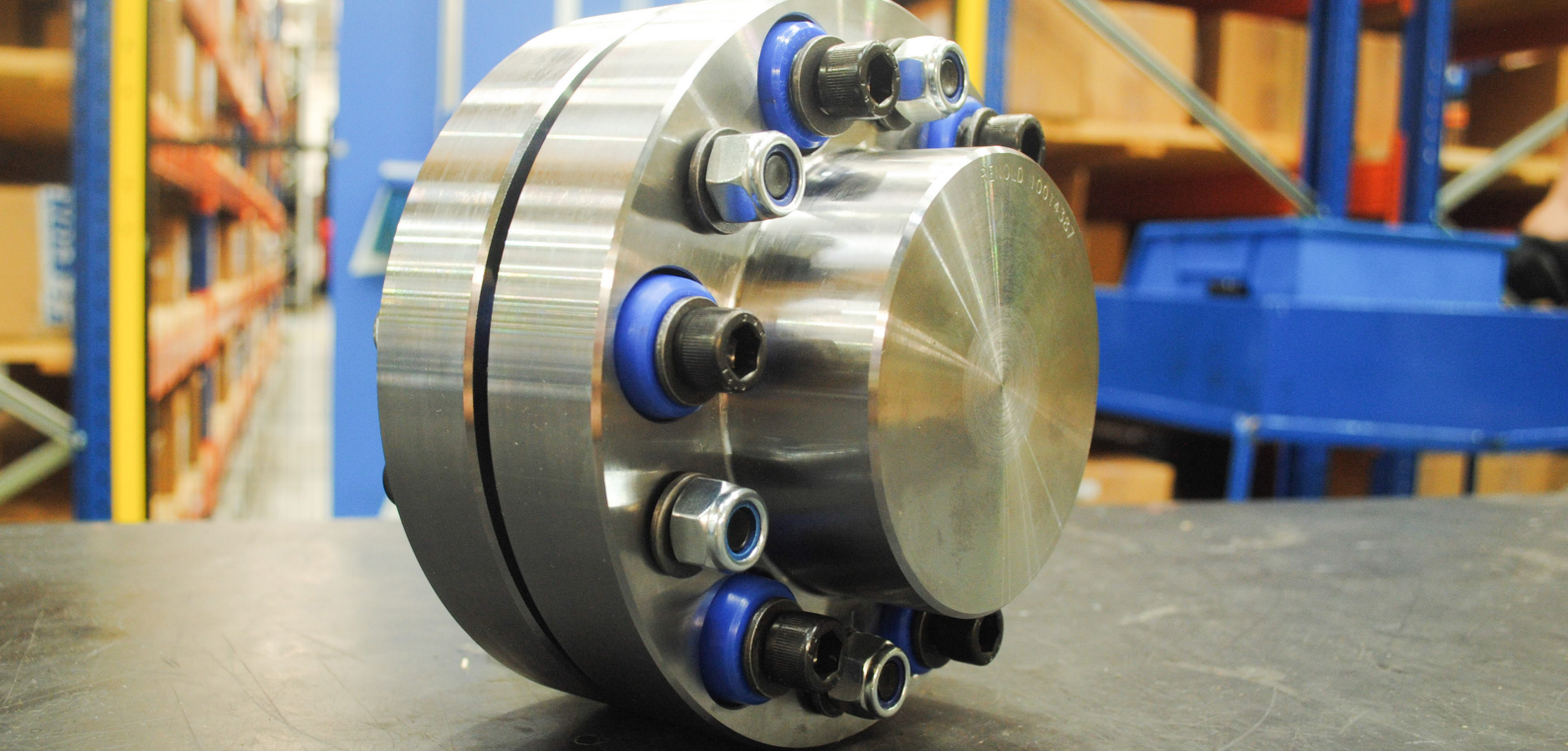

## Keyway dimensions

### Metric (mm)

Keyways comply with BS4235: Part 1: 1972

Shaft dia.		Keyway		
Over	Incl.	J	K	L
6	8	2	2	1.0
8	10	3	3	1.4
10	12	4	4	1.8
12	17	5	5	2.3
17	22	6	6	2.8
22	30	8	7	3.3
30	38	10	8	3.3
38	44	12	8	3.3
44	50	14	9	3.8
50	58	16	10	4.3
58	65	18	11	4.4
65	75	20	12	4.9
75	85	22	14	5.4
85	95	25	14	5.4
95	110	28	16	6.4
110	130	32	18	7.4
130	150	36	20	8.4
150	170	40	22	9.4
170	200	45	25	10.4
200	230	50	28	11.4

### Imperial (inches)

Keyways comply with BS46: Part 1: 1958

Shaft dia.		Keyway		
Over	Incl.	J	K	L
0.25	0.05	0.125	0.125	0.060
0.50	0.75	0.187	0.187	0.088
0.75	1.00	0.250	0.250	0.115
1.00	1.25	0.312	0.250	0.090
1.25	1.50	0.375	0.250	0.085
1.50	1.75	0.437	0.312	0.112
1.75	2.00	0.500	0.312	0.108
2.00	2.50	0.625	0.437	0.162
2.50	3.00	0.750	0.500	0.185
3.00	3.50	0.875	0.625	0.245
3.50	4.00	1.000	0.750	0.293
4.00	5.00	1.250	0.875	0.340
5.00	6.00	1.500	1.000	0.384

### Keyway dimensions

Parallel keyways are supplied unless customer states otherwise.

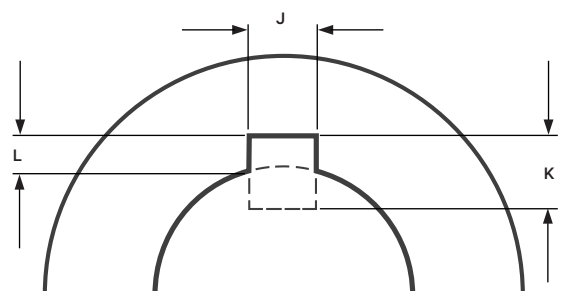

# Pinflex coupling dimensions

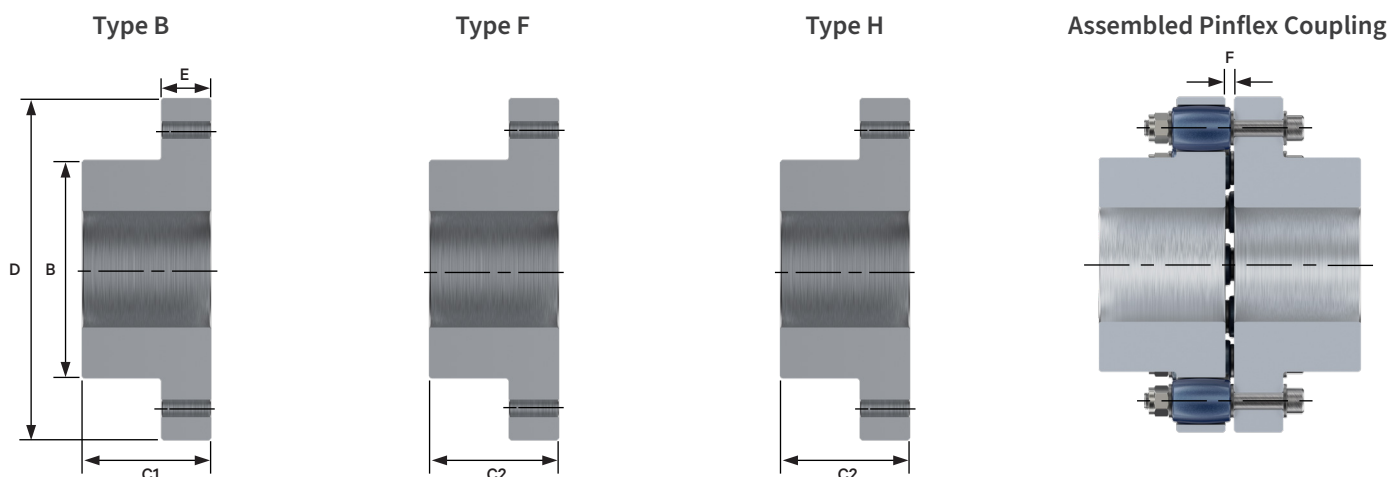

Catalogue number	Product number	Power/ 100rpm kW	Torque nominal Nm	Speed max rpm	Type B		Type F & H			Dimensions					Type B		Type F & H		
					Bore		Bush size	Bore		B mm	C1 mm	C2 mm	D mm	E mm	F mm	Mass* kg	WR <sup>2</sup> * kg m <sup>2</sup>	Mass* kg	WR <sup>2</sup> * kg m <sup>2</sup>
					Max	Min		Max	Min										
PF1# #3	8001042/3	2.03	194																
PF1# #6	8001042/6	4.05	387																
PF1BB9	8001042/9	6.08	581	6800	50	0	TB1215	32	11	70	44	40	125	20	4	5.2	0.00828	5.0	0.00813
PF1BB12	8001042/12	8.1	774																
PF2# #3	8002050/3	3.59	343																
PF2# #6	8002050/6	7.18	685																
PF2BB9	8002050/9	10.76	1028	5900	55	0	TB1615	42	14	80	50	40	145	25	5	8.3	0.01843	7.6	0.01780
PF2BB12	8002050/12	14.35	1370																
PF3# #3	8003060/3	4.24	405																
PF3# #6	8003060/6	8.48	810																
PF3BB9	8003060/9	12.71	1214	5200	72	0	TB2017	50	18	100	60	47	165	25	5	13.8	0.03335	12.1	0.03143
PF3BB12	8003060/12	16.96	1620																
PF4# #3	8004075/3	8.32	795																
PF4# #6	8004075/6	16.65	1590																
PF4BB9	8004075/9	24.97	2384	4400	80	0	TB2525	60	19	113	75	65	195	35	6	22.0	0.08470	20.3	0.08195
PF4BB12	8004075/12	33.29	3179																
PF5# #4	8005090/4	13.94	1331																
PF5# #8	8005090/8	27.88	2662																
PF5# #12	8005090/12	41.82	3994	3600	110	0	TB3030	75	35	150	89	80	235	35	6	37.8	0.19972	35.3	0.19274
PF5BB16	8005090/16	55.76	5325																
PF6# #3	8006110/3	24.70	2359																
PF6# #6	8006110/6	49.40	4717																
PF6# #9	8006110/9	74.10	7076	2900	130	55	TB3535	90	35	180	110	91	290	50	7	73.2	0.61140	65.2	0.58086
PF6BB12	8006110/12	98.80	9435																
PF7# #4	8807130/4	37.18	3550																
PF7# #8	8807130/8	74.35	7100																
PF7# #12	8807130/12	111.53	10650	2600	150	65	TB4040	100	40	210	130	105	320	50	7	103.0	0.99756	88.5	0.92310
PF7BB16	8807130/16	148.70	14200																
PF8# #4	8008150/4	64.70	6179																
PF8# #8	8008150/8	129.40	12357																
PF8# #12	8008150/12	194.10	18536	2200	175	75	N/A	N/A	N/A	245	150	130	380	60	7	168.8	2.33646	N/A	N/A
PF8BB16	8008150/16	258.80	24714																
PF9BB4	8009240/4	85.00	8130																
PF9BB8	8009240/8	170.00	16255																
PF9BB12	8009240/12	255.00	24385	1700	260	75	N/A	N/A	N/A	355	220	-	490	60	7	423.0	9.19000	N/A	N/A
PF9BB16	8009240/16	340.00	32500																

NOTE: Maximum power and torques for taper bore options are limited by the taper bush capacity.

\* Values are for couplings with no bore and a full set of pin assemblies.

Disc Brake Drum version also available - consult Renold for details.

Max angular misalignment 0.25°

Max offset misalignment 0.13mm





## Component spares

Coupling size	Half body pilot bored		Half body F type		Half body H type		Pin and buffer set	
	Catalogue number	Product number	Catalogue number	Product number	Catalogue number	Product number	Product number	Number per set
PF1	PF1 B	10014378	PF1 F	10014379	PF1 H	10014380	10010144	3
PF2	PF2 B	10014381	PF2 F	10014382	PF2 H	10014383	10010145	3
PF3	PF3 B	10014384	PF3 F	10014385	PF3 H	10014386	10010145	3
PF4	PF4 B	10014387	PF4 F	10014388	PF4 H	10014389	10010146	1
PF5	PF5 B	10014390	PF5 F	10014391	PF5 H	10014392	10010146	1
PF6	PF6 B	10014393	PF6 F	10014394	PF6 H	10014395	10010147	1
PF7	PF7 B	10014396	PF7 F	10014397	PF7 H	10014398	10010147	1
PF8	PF8 B	10014399	PF8 F	N/A	PF8 H	N/A	10010148	1
PF9	PF9 B	10014401	N/A	N/A	N/A	N/A	10010148	1

### Ordering code

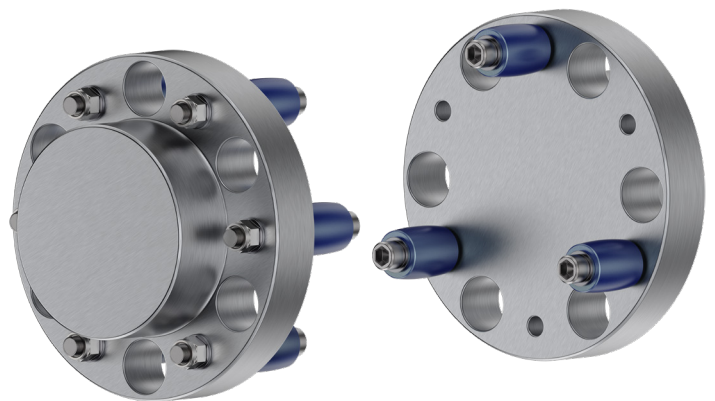
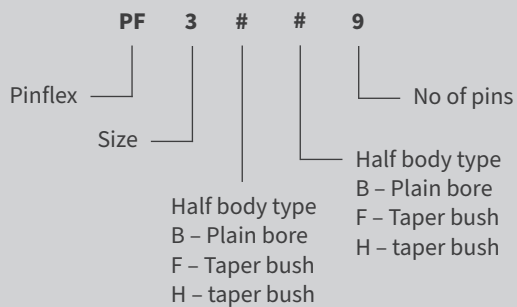

# Pinflex brakedrum coupling

Coupling size	Product number	Power/ 100rpm kW	Torque nominal Nm	Speed max rpm	Bore		Drum dimensions		
					A1 max mm	A2 max mm	Dia E mm	Width G mm	Dia E inch
PFBD1 #	8101042	8.1	774	3600	50	45	160	92	6
PFBD2 #	8102050	14.35	1370	2850	55	50	200	105	8
PFBD3 #	8103060	16.96	1620	2300	72	60	250	124	10
PFBD4 #	8104075	33.29	3179	1900	80	75	315	140	12
PFBD5 #	8105090	55.76	5325	1400	110	90	400	184	16
PFBD6 #	8106110	98.8	9435	1400	130	110	400	184	16
PFBD7 #	8107130	148.7	14200	1100	150	130	500	241	20
PFBD8 #	8108150	258.8	24714	900	175	150	630	267	24

Coupling size	Product number	Dimensions									Number of pins per coupling	Pin & buffer set	
		B1 mm	B2 mm	C1 mm	C2 mm	D mm	F mm	H mm	WR <sup>3</sup> kg m <sup>2</sup>	Mass kg		Part number	Number per set
PFBD1 #	8201042	70	70	44	44	125	4	-	0.0277	8.7	12	PFA	3
PFBD2 #	8202050	80	80	50	50	145	5	-	0.0696	14.3	12	PFB	3
PFBD3 #	8203060	100	100	60	60	165	5	-	0.1801	24.2	12	PFB	3
PFBD4 #	8204075	113	113	75	75	195	6	-	0.5487	49.0	12	PFC	1
PFBD5 #	8205090	150	150	90	90	235	6	-	1.6548	82.2	16	PFC	1
PFBD6 #	8206110	180	180	110	110	290	7	22	2.0706	114.1	12	PFD	1
PFBD7 #	8207130	210	210	130	130	320	7	13	5.2192	199.7	16	PFD	1
PFBD8 #	8208150	245	245	150	150	380	7	20	13.566	303.4	16	PFE	1

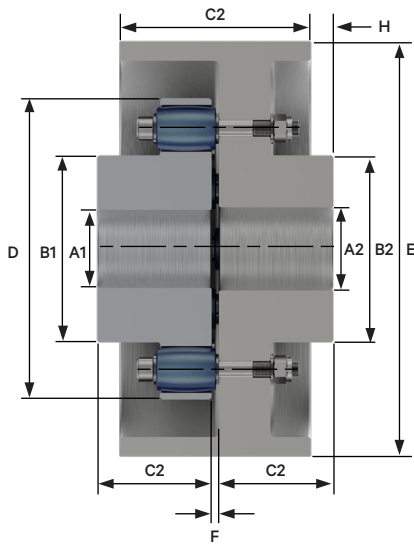

## Ordering code

**PF** **BD** **5** **#**  
 Pinflex ———  
 Brake drum ———  
 Size  
 M - Metric drum dia  
 B - Imperial drum dia

Disc brake version also available  
 – consult Renold for details



# Pinflex shearpin coupling

Coupling size	Nominal torque	Shear torque		Speed max rpm	Bore A1		Bore A2		Dimensions						No. of pins
		Min Nm	Max mm		Max mm	Min mm	Max mm	Min mm	B mm	C kg	D mm	E mm	F mm	Mass kg	
PFS1 #	387	194	774	6800	50	-	40	-	70	44	125	20	4	6.3	6
PFS2 #	685	220	1370	5900	55	-	47	-	80	50	145	25	5	10.1	6
PFS3 #	810	350	1620	5200	72	-	57	-	100	60	165	25	5	15.3	6
PFS4 #	1590	425	3180	4400	80	-	63	-	113	75	195	35	6	27.3	6
PFS5 #	2662	520	5324	3600	110	-	93	-	150	89	235	35	6	47.3	8
PFS6 #	4717	1100	9434	2900	130	55	107	55	180	110	290	50	7	89.8	6
PFS7 #	7100	2750	14200	2600	150	65	120	65	210	130	320	50	7	129	8
PFS8 #	12357	5900	24714	2200	175	75	147	75	245	150	380	60	7	212	8
PFS9 #	16255	8130	32510	1700	260	75	200	75	355	220	490	60	7	513	8

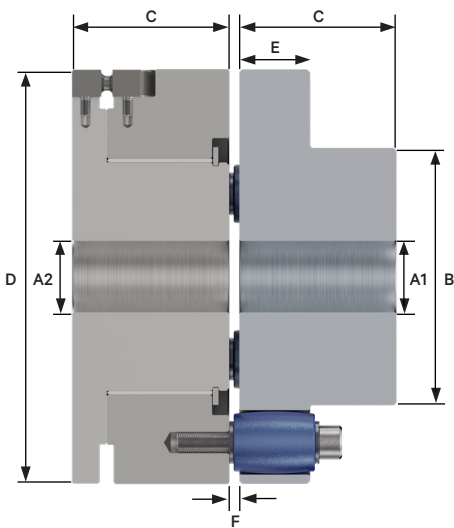

## Ordering code

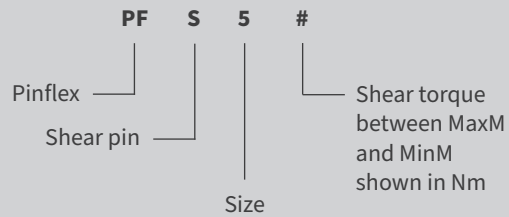

Select coupling based on nominal torque using service factors from page 13. Then select required shear torque from table below.

# Global services



 **Head office**    **Renold locations**



### Internal support

Sales team embedded in the manufacturing site with unrivalled product knowledge



### Large engineering team

Our team can design a quality coupling to match your exact requirements



### Manufacturing facility

Designed and manufactured in house by Renold; giving ultimate control on our solutions

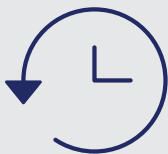

### History and Longevity

Manufacturing in the UK for over 100 years and commitment in our facilities for the long term, we are here to stay



### Excellent Communication

From an accessible sales team, weekly order updates and a global sales network we make it easy to communicate



### Record investment

Heavy investment in our business; spending millions of pounds upgrading CNC equipment, metrology arms and the newest software and test rigs



## Get in touch

For your local Renold  
sales and service location

+44 (0) 29 2079 2737



cardiff.sales@renold.com



www.renold.com



Wentloog Corporate Park  
Newlands Road, Cardiff  
CF3 2EU



**LRQA**  
CERTIFIED

ISO 9001

**LRQA**  
CERTIFIED

ISO 45001

**LRQA**  
CERTIFIED

ISO 14001